

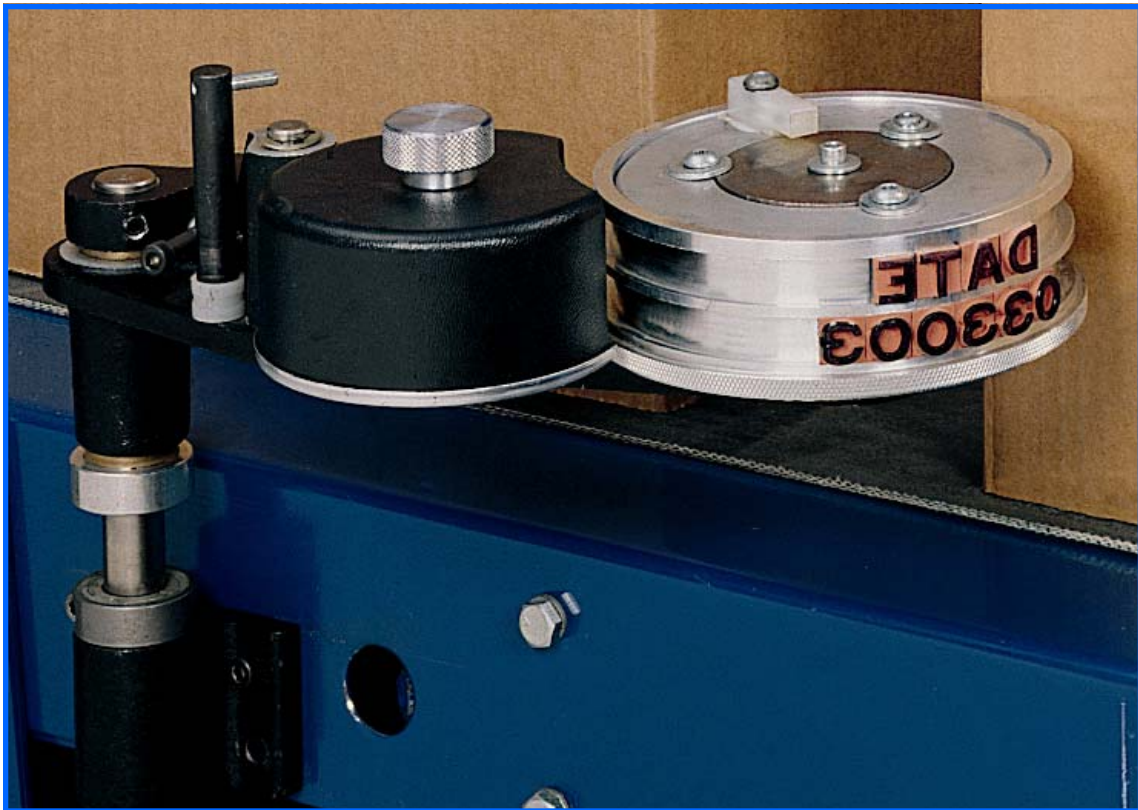

# SL-QC CODER PARTS LIST AND OPERATING INSTRUCTIONS



## **CONTENTS**

Installation	2
Operating Instructions	2-3
Maintenance	3
Problems & Corrections	4
Instructions for Mounting New Die Wheel & Die Wheel Shaft & Rotor Assembly	5-6
To Change From Left to Right Conveyor Mounting	7-8
Repair Parts List, SL-QC Coders (Table 1)	9-10
Dust Cover & Arm Assembly (Table 2)	11
Model SL-QC Cartridges (Table 3)	12

## INSTALLATION

1. The SL-QC Coder should be mounted so that the object to be printed contacts the die wheel with about 1/4" interference (see figure 1).



NOTE: The SL-QC Coder is presently set for left-hand mounting (see figure 3A.)

2. The mounting bracket assembly should be attached flush to the parent machine so the die wheel is parallel to the surface to be printed. When there are obstacles to mounting the SL-QC Coder directly to the parent machine, secure the SL-QC Coder mounting bracket to a slotted angle iron and then attach to the parent machine.
3. Light cases or objects not printed in the compressing section of a case sealer may require a support guide opposite the die wheel to keep cases or objects from shifting during the imprinting operation.

## OPERATING INSTRUCTIONS

1. Changing Type Holders—Turn the Ink Cartridge Cam to move the cartridge away from the die wheel. Turn the type holder latch 90 degrees to release the type holder. Remove the type holder by lifting from the die wheel. When replacing the type holder, return type holder latch to locked position. **IMPORTANT:** Return ink cartridge to print position by turning Ink Cartridge Cam (#9).
2. Positioning Type Holder Latch—The type holder latch may be positioned any place around the die wheel that is most convenient to the user. To reposition the type holder latch, loosen 3 screws. Move the latch to position desired and tighten screws. If multiple coders are used it may be helpful to set all the coders the same so the type holders may be interchanged from one coder to another and hold correct print registration.
3. Flex Base Type Changes—the flex base type holders are designed to grip the type on the ends when it is pressed into them. Pull old type out and install new type by starting one end into type holder and pressing firmly in and down on the other end until type is solid against bottom of type holder.

4. XLM, Didark, and Foam Ink Cartridge Replacement (see page 12) - Remove cartridge from ink roll shaft and install new or re-inked cartridge on shaft.
5. Adjustment of inking cartridge against type - The ink roller assembly is mounted on an adjustable spring-loaded bracket. Loosen wing nut, which locks adjustable thumb screw on bracket. Turn screw in or out, depending on adjustment required. When adjustment is correct, tighten wing nut. A “kiss-contact” is all that is needed.
6. Adjustment for pressure against object to be imprinted (see figure 1) - To obtain more printing pressure, place spring in a hole position farther to the end of the return arm (#7).

## **MAINTENANCE**

1. To change type, cartridge, or for service, move the unit away from the carton flow. A quick and simple means is provided in the unit’s design as follows (see figure 4). Grasp the Base Plate (#14) at the mounting end and lift upward away from the mounting bracket assembly (#3) until the collar (#4) is clear of the locating pin. Swivel the unit until clear of carton flow. The unit can now be serviced as needed. Return the unit to its original position with the locating pin resealed into the groove of the collar. The unit is now in its original print position.
2. The unit and type must be kept clean for good imprinting.
3. No hydrocarbon solvents should be permitted in contact with the rubber type or roller. To prevent damage to type or cartridges use only inks or cleaners recommended by Diagraph MSP.

## PROBLEMS AND CORRECTIONS

### PARTIAL IMPRESSIONS

1. Check the cartridge and type contact for complete inking.
2. Check cartridge for sufficient ink.
3. Check for worn, damaged, or improperly seated type.
4. Check SL-QC Coder for sufficient pressure against object to be printed.
5. Check that die wheel imprint surface is parallel to surface being printed.
6. Make certain SL-QC Coder is mounted rigidly.
7. Check for "Hill and Valley" type. (Type may not be fitted to die wheel properly.)

### VERY HEAVY IMPRESSIONS

1. Check excessive pressure between ink roll and type face.
2. Check for over-inked system.

### LOCATION OF IMPRESSION WANDERS WITH RELATION TO OBJECT BEING PRINTED (See Figures 1 & 2)

1. Check for loose screw on top of die wheel.
2. Check for insufficient pressure between SL-QC Coder and object to be printed.
3. Check for loose hex nut (see Figure 2).



FIGURE 1

**INSTRUCTIONS FOR MOUNTING NEW DIE WHEEL ASSEMBLY AND DIE WHEEL SHAFT AND ROTOR ASSEMBLY (Figure 2)**

1. Remove Hex Nut.
2. Loosen screw approximately 1/4". Tap screw lightly to break die wheel loose from shaft.
3. Remove screw, washer, and die wheel.
4. Remove nut and compression spring from Latch Assembly (#22).



**CAUTION:** This nut is under slight spring tension and should be removed with a nut driver or socket wrench to prevent injury.

5. Remove shaft and rotor assembly (#18).
6. Install new shaft and rotor assembly.
7. Replace Hex Nut.
8. Replace compression spring and nut on Latch Assembly.



**IMPORTANT!** Use nut driver to replace nut since the spring must be compressed during installation.

9. Replace new die wheel assembly.
10. Replace washer and screw.

FOR ILLUSTRATION PURPOSES ONLY. REFER TO FIGURE 4 FOR PARTS BREAKDOWN OF ITEMS REQUIRED.

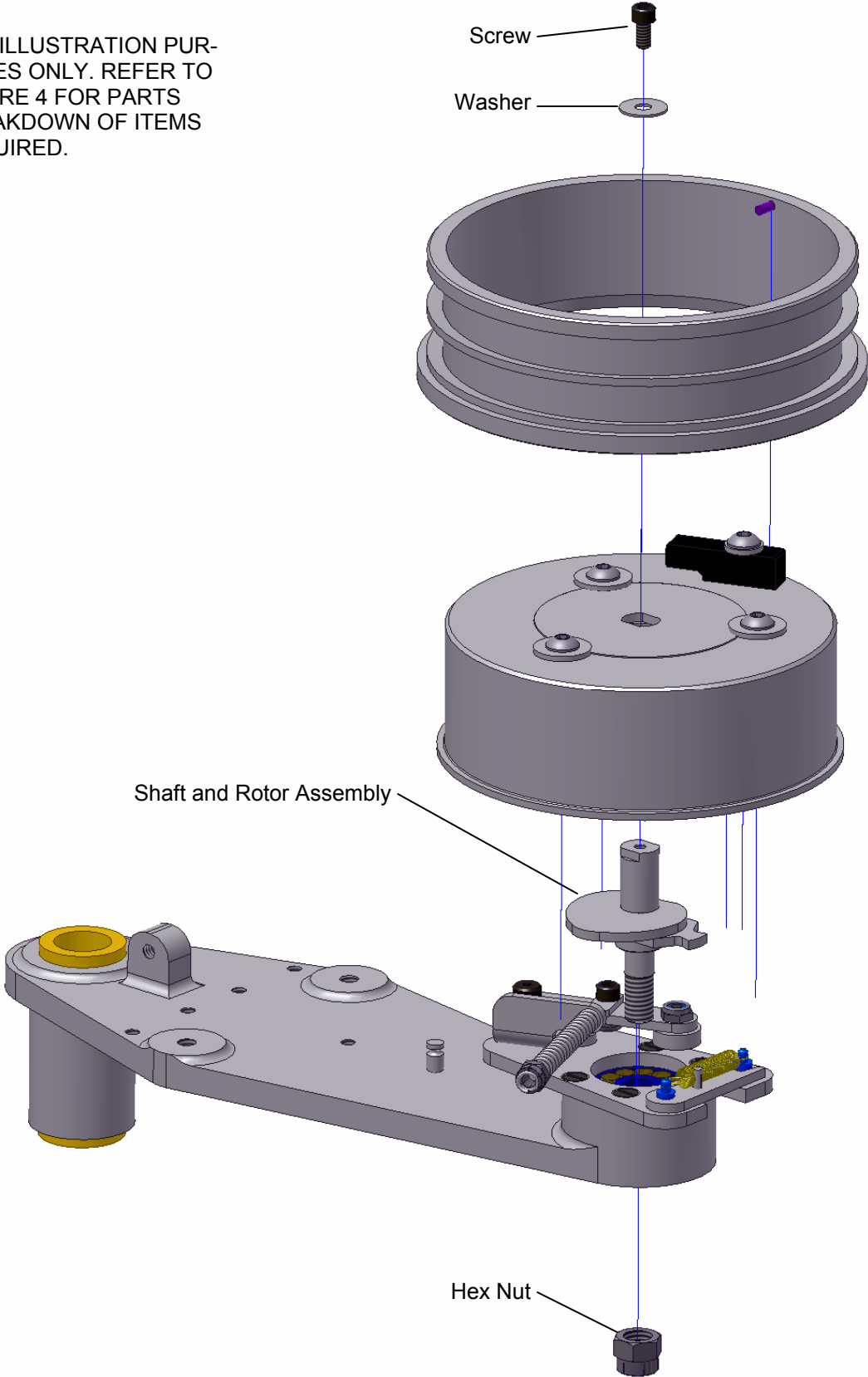

FIGURE 2

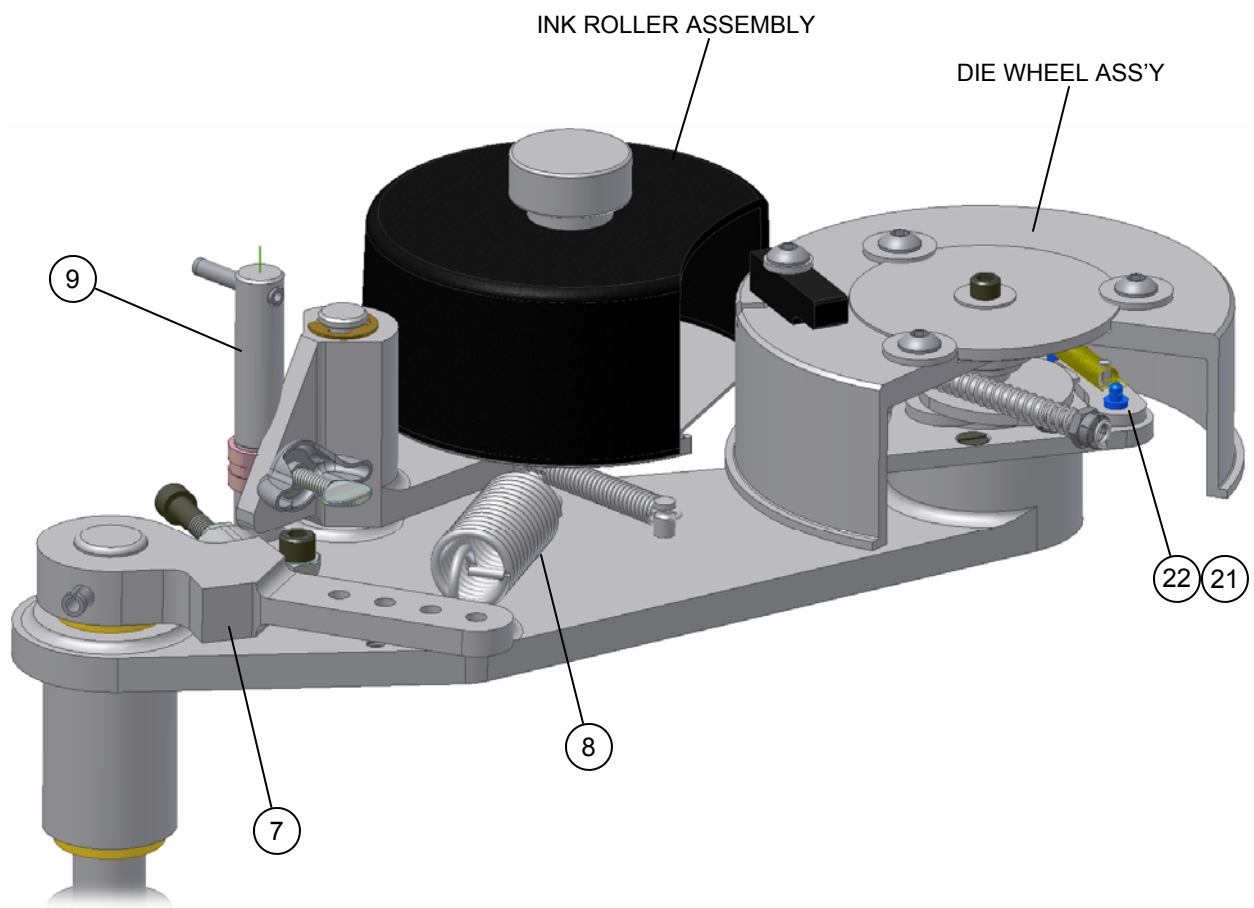

FIGURE 3A LEFT HAND (STANDARD FACTORY SET)

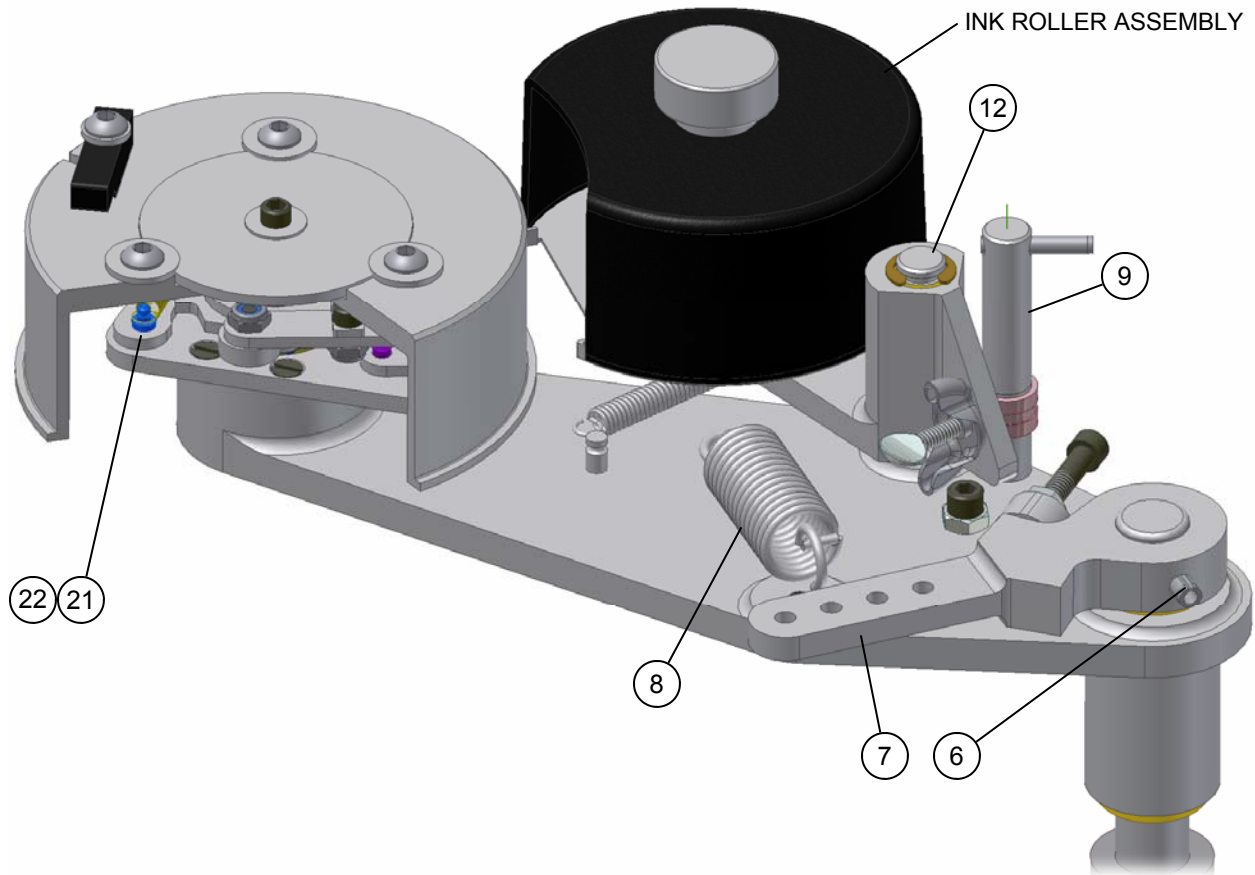

FIGURE 3B RIGHT HAND

**TO CHANGE THE CONVEYOR MOUNTING FROM LEFT TO RIGHT (Figures 3A & 3B)**

1. Loosen screw and remove die wheel assembly.
2. Remove latch spring (#21).
3. Reverse latch assembly (#19) as shown.
4. Dust cover and arm assembly, ink roll pivot shaft (#12), stop pin and wing nut must be reversed as shown.
5. Reverse adjusting nut & screw and return arm (#7).
6. Move roll pin (#6) to opposite side of return arm.

TABLE 1

**Repair Parts List**

REF. NO.	STOCK NO.	DESCRIPTION	QTY. REQ'D
1	1789010	COLLAR, CLAMP TITE	2
2	1709144	SPRING SLEEVE	1
3	1730859	MOUNTING BRACKET ASM.	1
4	1730040	COLLAR	1
5	1789009	SHAFT SUPPORT	1
6	5315050	ROLL-PIN ¼ DIA. X 2	1
7	1789039	RETURN ARM	1
8	1789044	SPRING	1
9	1730803	CARTRIDGE CAM ASM.	1
10	1709006	E-RING BOWED	1
11	1781802	DUST COVER & ARM ASM. #1	1
	1782802	DUST COVER & ARM ASM. #2	
12	1789008	SHAFT, PIVOT ARM	1
13	1789002	PIN, RETAINER	1
14	1789804	BASE PLATE ASM.	1
15	1709107	PLUG	1
16	1730805	TYPE HOLDER QC HI-SPEED	A/R
	1730808	TYPE HOLDER, QC FTH 2-LINE ½"	
	1730809	TYPE HOLDER, QC FTH 1-LINE 5/8"	
	1730810	TYPE HOLDER, QC FTH 1-LINE ¾"	
	1730813	TYPE HOLDER, QC LINCOLN	
	1730816	TYPE HOLDER, QC DILOK #1	
17	1730817	TYPE HOLDER, QC DILOK #2	
17	1730826	DIE WHEEL & WASHER ASM.	1
18	1730825	SHAFT & ROTOR ASM.	1
19	1780805	SPRING RETURN ASM.	1
20	5191506	SCREW 8-32 X 7/16 Fl. Hd. SI.	4
21	1709017	SPRING LATCH	1
22	1789805	LATCH ASM	1
23	1789806	BASE ASM.	1
24	5082109	SCREW, ¼-28 X 5/8 Soc. Hd.	A/R

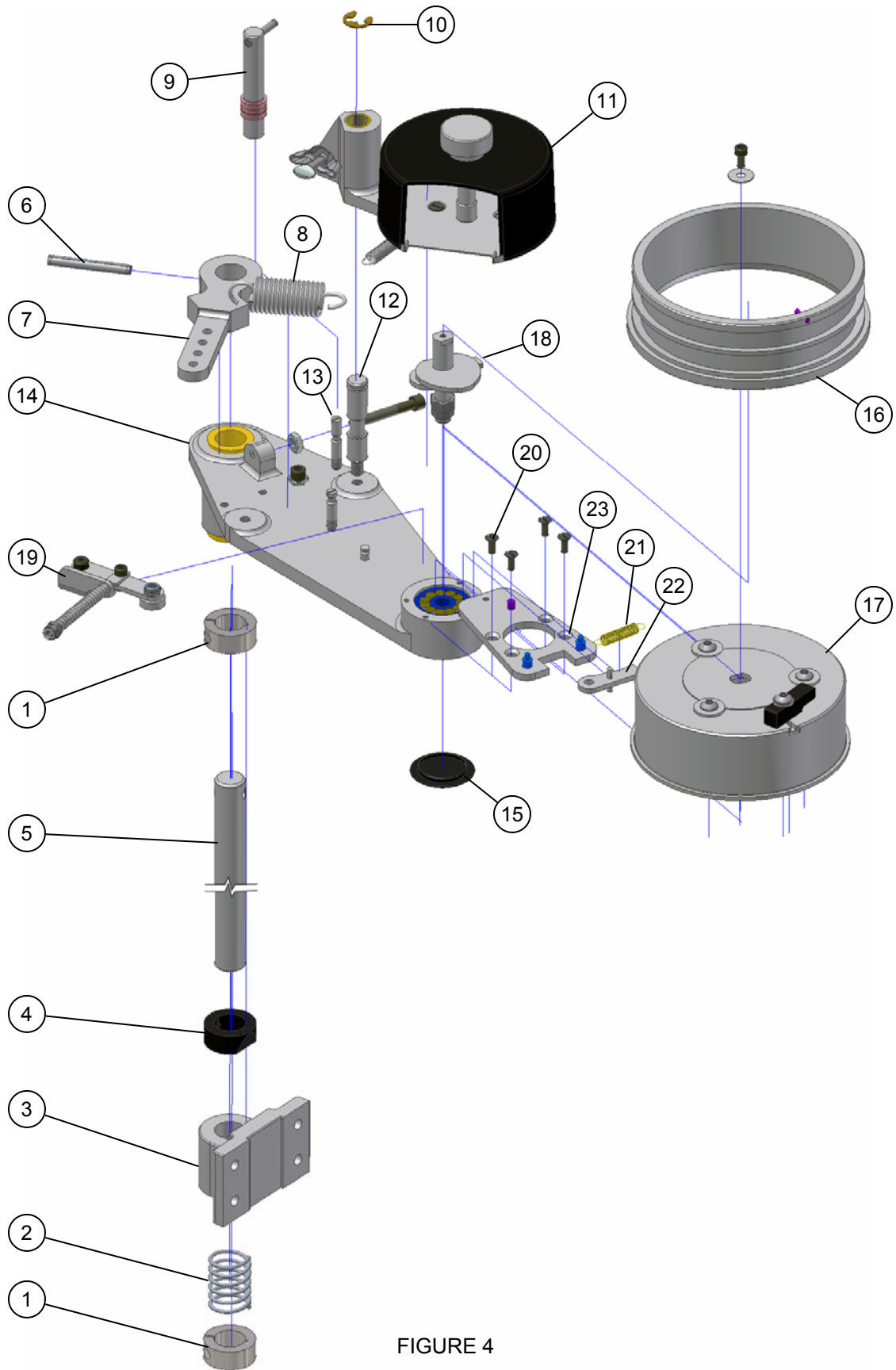

FIGURE 4

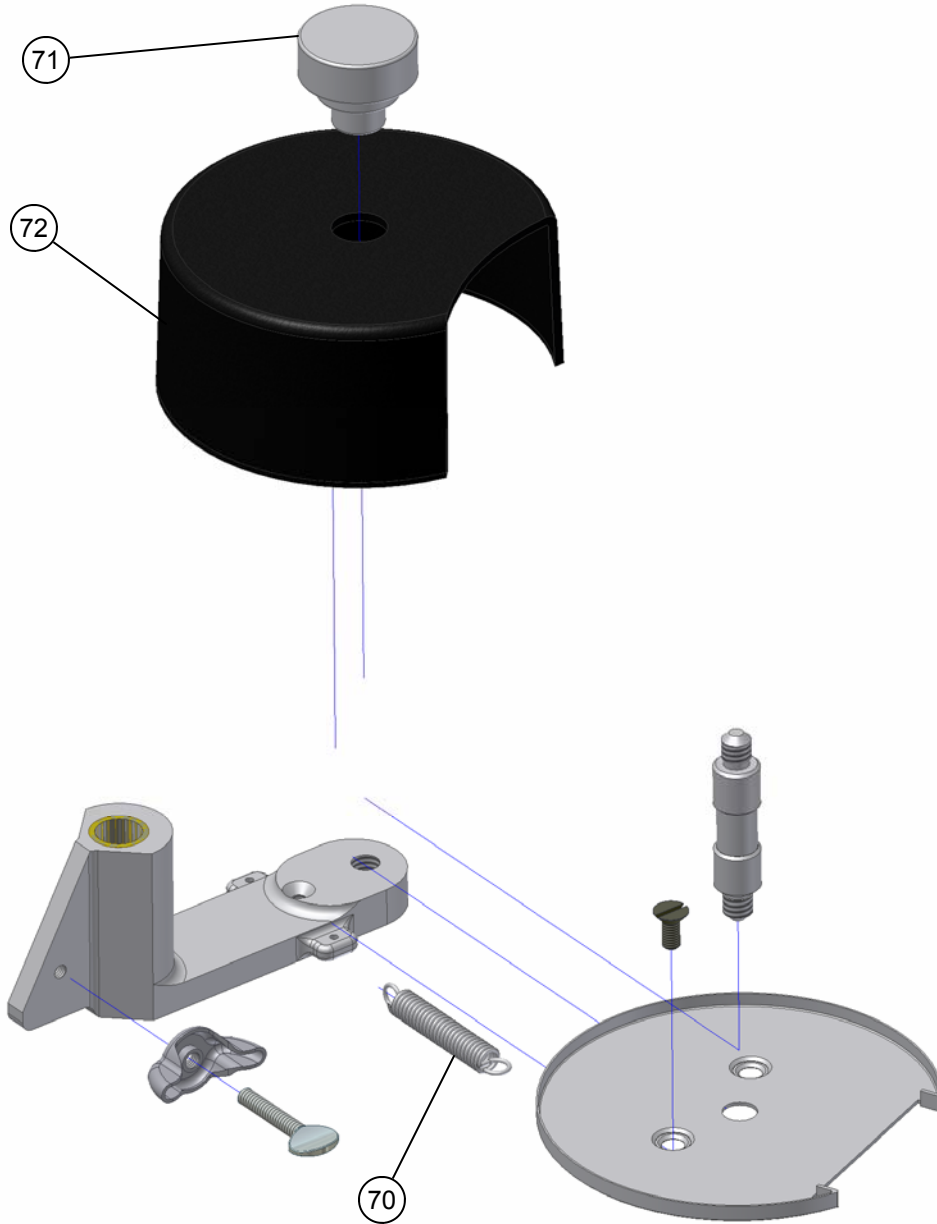

FIGURE 5

TABLE 2

DUST COVER & ARM ASSEMBLY			
REF. NO.	STOCK NO.	DESCRIPTION	NO. REQ'D.
70	1789-005	Spring	1
71	1789-062	Knob	1
72	1781-002	Dust Cover #1	1
	1781-103	Dust Cover #2	
	1781-004	Dust Cover #3	



DIDARK



XLM



FOAM



MICRO-X

Table 3

**Model SL-QC Cartridges**

<b>DIDARK INK CARTRIDGE</b>		
STOCK NO.	DESCRIPTION	NO. REQ'D.
1714-100	Cartridge, DiDark #1 Uninked	1
1714-101	Cartridge, DiDark #1 Black	1
1714-102	Cartridge, DiDark #1 Red	1
1715-100	Cartridge, DiDark #2 Uninked	1
1715-101	Cartridge, DiDark #2 Black	1
1716-100	Cartridge, DiDark #3 Uninked	1
1716-101	Cartridge, DiDark #3 Black	1
<b>XLM INK CARTRIDGE</b>		
1719-100	Cartridge, XLM #1 Uninked	1
1719-101	Cartridge, XLM #1 Black	1
1719-103	Cartridge, XLM #1 Red	1
1719-200	Cartridge, XLM #2 Uninked	1
1719-201	Cartridge, XLM #2 Black	1
1719-300	Cartridge, XLM #3 Uninked	1
1719-301	Cartridge, XLM #3 Black	1
<b>FOAM CARTIDGE</b>		
1717-801	Cartridge, Foam #1	1
1717-802	Cartridge, Foam #2	1
1717-803	Cartridge, Foam #3	1
<b>MICRO-X CARTRIDGE</b>		
1701-401	Cartridge, Micro-X #1 Black	A/R
1702-401	Cartridge, Micro-X #2 Black	A/R
1703-401	Cartridge, Micro-X #3 Black	A/R