

HOUSED MODEL STENCIL CUTTING MACHINE

PARTS LIST AND OPERATING MANUAL



OPERATING INSTRUCTIONS

1. Before beginning operation, make sure that no punches have become stuck in their dies during shipment. Separate stuck dies by prying them apart with a screwdriver.
2. Make sure the hand wheel rotates freely.
3. Rotate the cam lever, located at the front of the machine's base, until it points upward, releasing the pressure between the upper and lower feed wheels. Your machine is now ready to insert the stencil board.

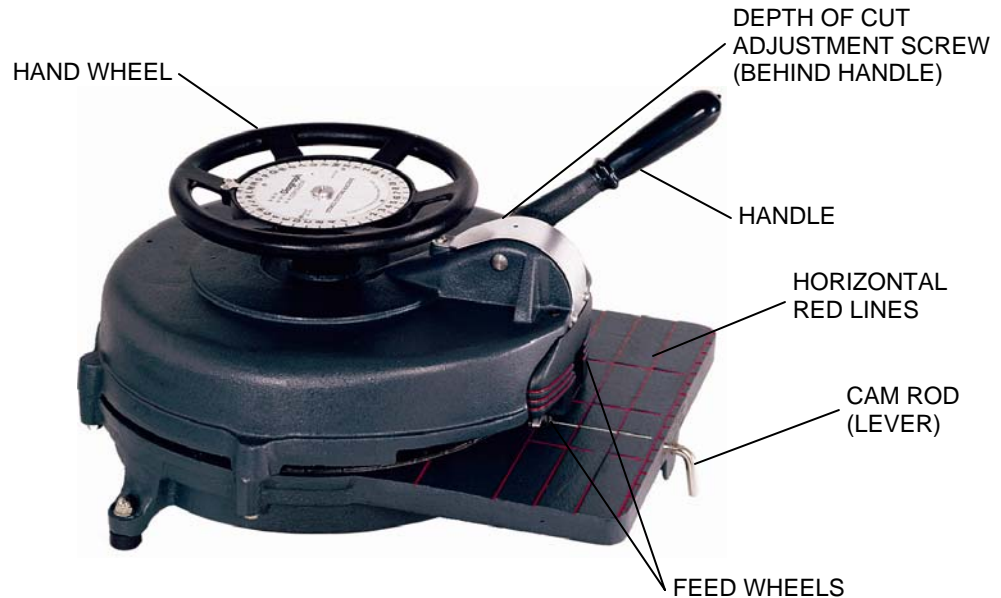

Figure 1, Stencil Cutting Machine

4. Insert the stencil board between the upper and lower feed wheels and base with the left hand edge of the board aligned with the white line on the base. Align the edge of the board nearest the operator with one of the red horizontal lines in the base.

Note: Normally, multiple line cut stencils require that the red line nearest the operator represents the first line to be cut.

5. Rotate the cam lever downward to secure the stencil board between the upper and lower feed wheels to secure the stencil board.
6. Rotate the hand wheel until the pointer points to the desired character. Cut by pulling the handle with a firm, quick motion. Return the handle to its full upward position before continuing to the next character.
7. To use the spacing character, pull the handle approximately halfway down until a definite clicking sound is heard.
8. To cut successive lines repeat steps 2, 3, 4 and 5 while advancing the stencil to the next horizontal red line on the base to produce a new line of text.

PROBLEMS AND CORRECTIONS

CHARACTER DOES NOT CUT

1. Adjust the stop screw on the hood to lengthen the stroke of the handle. This will provide a deeper penetration of the punch into the die.



CAUTION: Make this adjustment in small increments because excessive penetration may cause other punches to stick in their dies. Difficulty in operating the machine and premature failure may result.

1. Inspect punch and die for paper segments. Remove any obstructions with the cleaning hook provided.
2. If the actions above fail to correct the problem, contact the nearest Diagraph sales office for assistance.

IMPROPER SPACING

1. Inspect the knurled upper feed rollers for paper clogs and clean with a wire brush.
2. Check to see that the upper and lower feed rollers rotate freely.
3. If the characters are spaced too closely together, it may be necessary to readjust the mounting of the upper feed assembly.
 - A. Release pressure between the upper and lower feed rollers.
 - B. Loosen the two screws which secure the upper feed casting to the hood.
 - C. Push the upper feed roller toward the operator's left, then tighten the mounting screws.
4. If characters are spaced too far apart, repeat step 3 and reposition the upper feed assembly toward the operator's right.
5. If the above suggestions fail, contact the nearest Diagraph sales office for assistance.

STENCIL BOARD NOT FEEDING STRAIGHT

If this occurs when replacing the lower feed assembly or when the machine is out of adjustment, refer to the "Lower Feed Adjustment" section.

MAINTENANCE

1. To ensure the maximum life of punches and dies and to minimize maintenance and repairs, use only the stencil board specifically formulated and processed by Diagraph



CAUTION: Do not attempt to cut metal. This will permanently damage the machine.

2. Periodically examine the punches and dies for particles of clogged stencil board and remove with the cleaning hook.
3. Routinely lubricate all moving parts with a lightweight grade of machine oil.

PUNCH AND DIE REPLACEMENT

Replacement of a punch and die should be performed by qualified personnel. Improper procedures during installation can result in damaged components. Carefully follow the steps below:

1. Turn the machine upside down, letting it rest on the hand wheel with the base table facing you.
2. Rotate the machine until the damaged character aligns with the cutout portion in the base.



Figure 2, Punch & Die Assembly

3. With a screwdriver, remove the two screws securing the die and slide die out, being careful not to drop the screws or die into the machine.
4. Insert the screwdriver through the holes in the die carrier and remove the two screws securing the punch, being careful not to drop the screw or punch into the machine.
5. Note the positioning of the color coded markings on the new punch and die and separate them by carefully prying them apart.

6. Place punch screws into new punch and carefully slide punch into its mounting position with the color code facing outward from the center of the machine. Tighten the screws inserted through the holes in the die carrier.
7. Carefully place die on punch and make certain the color coded markings are aligned. Apply very slight pressure to start the die mating with the punch.
8. Raise the punch until the die is against the die carrier. Insert the die mounting screws and washers and tighten screws alternately, a little at a time.

LOWER FEED ADJUSTMENT

ADJUSTMENT OF RIGHT HAND

1. Disengage pressure between upper and lower feed rollers.
2. Loosen jam nut just enough to allow movement of screws.
3. After making a stencil, turn right adjustment screw clockwise. The stencil board will move towards the operator.
4. Turn left adjustment screw counterclockwise. The stencil board will move toward the operator.
5. Once stencil board is in line, hold adjustment screw in place and tighten jam nut.

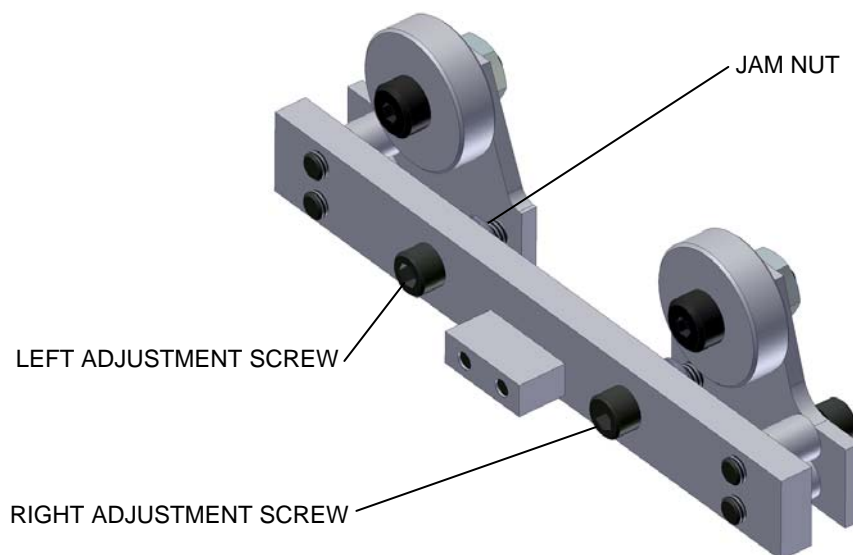
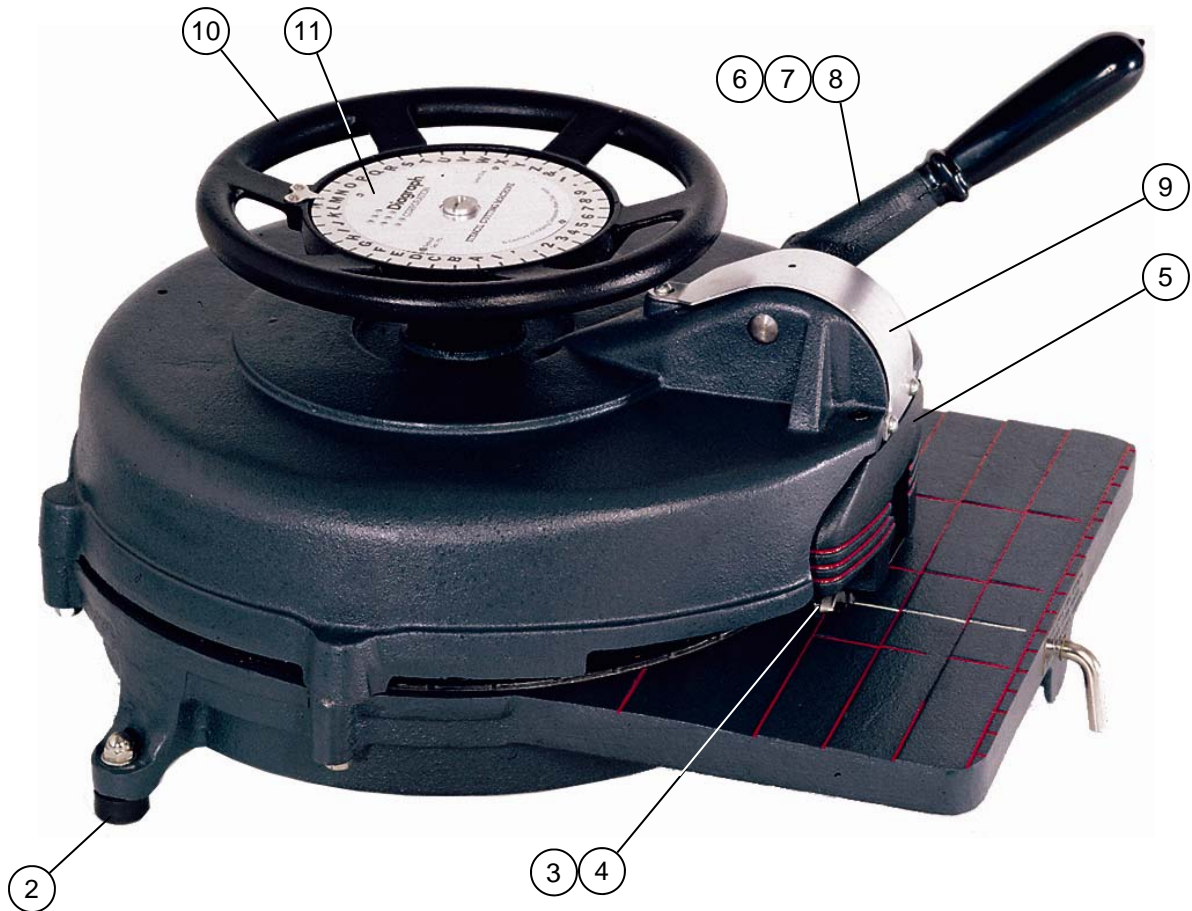

Figure 3, Roller Adjustment



CAUTION: Adjust one roller at a time. Start with right roller, gently turn adjustment screw 1/8 to 1/4 of a turn.

HOUSED MODEL PARTS LIST



Ref.#	Stock #	Description	Req'd
1	---	Punch & Die (see page 7)	---
2	0109-159	Feet, Rubber	3
3	0109-801	Lower Feed, Adjustable	1
4	0109-214	Spring, Lower Feed	2
5	0101-805	Upper Feed Assembly, 1/8" machine	1
	0102-805	Upper Feed Assembly, 1/4" machine	
	0104-805	Upper Feed Assembly, 1/2" machine	
	0107-805	Upper Feed Assembly, 3/4" & 1" machine	
6	0109-244	Spring, Handle Return	1
7	0109-867	Lever, Yoke Assy, Standard	1
8	0109-871	Handle Assembly	1
9	0109-173	Plate, Cover	1
10	0109-865	Hand Wheel Assembly	1
11	0109-866	Etched Dial Assembly	1
12	0109-223	Cleaning Hook (not shown)	1

PUNCH & DIE ASSEMBLY NUMBERS

(For special punches & dies, contact customer service)



Punch & Die screws are not included with Punch & Die Assemblies.

Character	1/8"	1/4"	1/2"	3/4"	1"	2"
A	0101-200	0102-200	0104-200	0107-200	0105-200	0120-200
B	0101-201	0102-201	0104-201	0107-201	0105-201	0120-201
C	0101-202	0102-202	0104-202	0107-202	0105-202	0120-202
D	0101-203	0102-203	0104-203	0107-203	0105-203	0120-203
E	0101-204	0102-204	0104-204	0107-204	0105-204	0120-204
F	0101-205	0102-205	0104-205	0107-205	0105-205	0120-205
G	0101-206	0102-206	0104-206	0107-206	0105-206	0120-206
H	0101-207	0102-207	0104-207	0107-207	0105-207	0120-207
I	0101-208	0102-208	0104-208	0107-208	0105-208	0120-208
J	0101-209	0102-209	0104-209	0107-209	0105-209	0120-209
K	0101-210	0102-210	0104-210	0107-210	0105-210	0120-210
L	0101-211	0102-211	0104-211	0107-211	0105-211	0120-211
M	0101-212	0102-212	0104-212	0107-212	0105-212	0120-212
N	0101-213	0102-213	0104-213	0107-213	0105-213	0120-213
O	0101-214	0102-214	0104-214	0107-214	0105-214	0120-214
P	0101-215	0102-215	0104-215	0107-215	0105-215	0120-215
Q	0101-216	0102-216	0104-216	0107-216	0105-216	0120-216
R	0101-217	0102-217	0104-217	0107-217	0105-217	0120-217
S	0101-218	0102-218	0104-218	0107-218	0105-218	0120-218
T	0101-219	0102-219	0104-219	0107-219	0105-219	0120-219
U	0101-220	0102-220	0104-220	0107-220	0105-220	0120-220
V	0101-221	0102-221	0104-221	0107-221	0105-221	0120-221
W	0101-222	0102-222	0104-222	0107-222	0105-222	0120-222
X	0101-223	0102-223	0104-223	0107-223	0105-223	0120-223
Y	0101-224	0102-224	0104-224	0107-224	0105-224	0120-224
Z	0101-225	0102-225	0104-225	0107-225	0105-225	0120-225
&	0101-226	0102-226	0104-226	0107-226	0105-226	0120-226
-	0101-227	0102-227	0104-227	0107-227	0105-227	0120-227
.	0101-228	0102-228	0104-228	0107-228	0105-228	0120-228
/	0101-229	0102-229	0104-229	0107-229	0105-229	0120-229
2	0101-230	0102-230	0104-230	0107-230	0105-230	0120-230
3	0101-231	0102-231	0104-231	0107-231	0105-231	0120-231
4	0101-232	0102-232	0104-232	0107-232	0105-232	0120-232
5	0101-233	0102-233	0104-233	0107-233	0105-233	0120-233
6	0101-234	0102-234	0104-234	0107-234	0105-234	0120-234
7	0101-235	0102-235	0104-235	0107-235	0105-235	0120-235
8	0101-236	0102-236	0104-236	0107-236	0105-236	0120-236
9	0101-237	0102-237	0104-237	0107-237	0105-237	0120-237
'	0101-238	0102-238	0104-238	0107-238	0105-238	0120-238
,	0101-239	0102-239	0104-239	0107-239	0105-239	0120-239

DIAGRAPH STENCIL BOARD

Diagraph Stencil Board is made from the finest raw stock, processed under special formula with double-boiled linseed oil and cured in our own plant. The use of Diagraph oiled stencil board extends the life of Diagraph cutters by lubricating the punches and dies. Diagraph stencil board resists absorption of ink and can be used over and over again. All stencil board is cut long grain to provide rigidity for ease of use. Diagraph stencil board conforms to government specifications UU-S-625A in Type II Grade 1.

DISPENS-A-PAK NO. 25 (23 LBS. NET)

Dispens-A-Pak is easy to handle and store. The package protects the board and serves as its own dispenser.

PARCEL-PAK NO. 50 (50 LBS. NET)

To expedite handling and shipping by UPS, this carton of Diagraph Stencil Board has been designed so the total weight of the carton and contents equal 50 lbs.

Sheet Size		Packed in Parcel packs	
Inches	Millimeters	Approx. Pieces per Pound	Approx Pieces per Kilo
4 x 20	101.6 x 508	20	44
5 x 20	127 x 508	16	35.2
6 x 20	152.4 x 508	14	30.8
6.5 x 20	165.1 x 508	12	26.4
6.5 x 24	164.1 x 609.6	10	22
7 x 20	177.8 x 508	10	22
7 x 24	177.8 x 609.6	9	19.8

Standard Cut Sizes of Oiled Stencil Board and Approximate Pieces per Pound/Kilo

Sheet Size		Packed in Parcel packs	
Inches	Millimeters	Approx. Pieces per Pound	Approx Pieces per Kilo
11 x 36	279.4 x 914.4	4	8.8
24 x 36	608.6 x 914.4	1.75	3.85
24 x 40	609.6 x 1016	1.5	3.3

STENCIL BOARD SIZE SELECTOR GUIDE

Based on Letter Height and Number of Lines

Letter Height	1 Line	2 Lines	3 Lines	4 Lines	5 Lines	6 Lines	7 Lines	8 Lines	9 Lines	10 Lines
1/4" 6mm	4" 102mm	4" 102mm	4" 102mm	4" 102mm	4" 102mm	5" 127mm	5" 127mm	6" 152mm	6" 152mm	6.5" 166mm
1/2" 13mm	4" 102mm	4" 102mm	4" 102mm	5" 127mm	6" 152mm	6.5" 166mm				
3/4" 19mm	4" 102mm	4" 102mm	5" 127mm	6.5" 166mm						
1" 25mm	4" 102mm	5" 127mm	6" 152mm	6.5" 166mm						
2" 50mm	4" 102mm	7.5" 191mm	11" 179mm							

STENCIL MACHINE CHARACTER SIZES AND SPECIFICATIONS

Letter Height		Letters per Foot	Max # of Lines	Height	Weight		Length in Inches	Width in Inches	Height in Inches	Shipping Pounds	Weight Kilos
Inches	MM				Pounds	Kilos					
1/8	3.1	81	14	4-1/8"	75	34.1	23-1/2"	19'	14"	90	40.82
1/4	6.3	45	10	4-1/2"	75	34.1	23-1/2"	19"	14"	90	40.82
1/2	12.7	22	6	4-1/2"	75	34.1	23-1/2"	19"	14"	90	40.82
3/4	19.05	15	4	4-1/2"	76	34.1	23-1/2"	19"	14"	90	40.82
1	25.4	15	4	5"	75	34.1	23-1/2'	19"	14"	90	40.82
2	50.8	8	3	7	210	95.5	42'	28-1/2"	18.5"	225	102.3